

Donaldson®
Torit®

**DOWNFLO® OVAL
DUST COLLECTORS**

ULTRA-WEB®
High Efficiency **Nanofiber Filters** Built to Last



A FAMILY OF OVER-ACHIEVERS

The high performance Downflo® Oval (DFO) family of over-achieving dust collectors provides up to 25 percent more filtration capacity than other same-sized cartridge collectors. Powered by proprietary Ultra-Web® nanofiber filtration technology, DFO delivers cleaner air, up to two times longer filter life, and greater cost savings.

The DFO advantage is found in the collector's proprietary design and components. The combination of a new cabinet design that greatly lowers cabinet velocities, proprietary Extra-Life™ cleaning technology, and proven Ultra-Web nanofiber filters allows more airflow through the collector without increasing the size of the footprint or damaging the filters.

A smaller collector helps lower the initial purchase price, reduces filter replacement costs and opens up valuable manufacturing floor space.

DFO offers:

- Lower initial cost per cubic foot of air per minute
- Higher efficiency—cleaner air
- Lower pressure drop— greater energy savings
- Fewer filter changeouts
- Reduced filter disposal cost
- Easy system setup
- Less maintenance
- 10-year warranty

25%
MORE CAPACITY



OUTPERFORMS ALL OTHER COLLECTORS

DFO collectors offer some strong benefits that distinguish them from all other collectors available in the market today.

EASY TO USE

Quick-release handles provide easy cover removal and faster filter access

COMPACT

Smaller footprints for applications that require maximum cleaning efficiency in even smaller spaces

POWERFUL

DFO collectors provide 25 percent more capacity than same-sized dust collectors

COST EFFECTIVE

The proprietary ExtraLife™ Filter Cleaning System averages up to 30 percent increase in pulse cleaning energy for unmatched cleaning ability

INNOVATIVE

Unique oval-shaped Ultra-Web® cartridge filters provide the longest filter life and highest filtration efficiency—which lowers cost



DFO 2-4



DFO 3-3

SIZES & OPERATIONS

DFO Models 1-1, 2-2 and 3-3

- Incorporate several exclusive and unique features
- Completely self-contained, “plug-and-play” type units
- Packaged with power pack, controls, silencer, damper, dust container and more
- Remarkably quiet operation
- Exceptionally compact design
- Easily movable through standard aisles and doorways

NORMAL OPERATIONS FOR MODELS 1-1, 2-2 AND 3-3

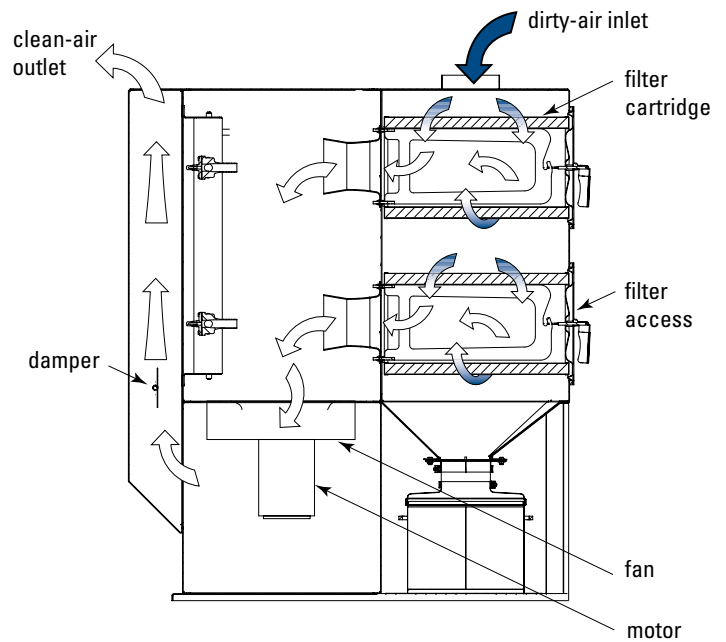

DFO Models 2-4 to 4-128

- 23 standard model sizes
- Customized sizes available
- Many options and accessories
- Exceptionally compact design
- Significant energy savings

NORMAL OPERATIONS FOR MODELS 2-4 TO 4-128

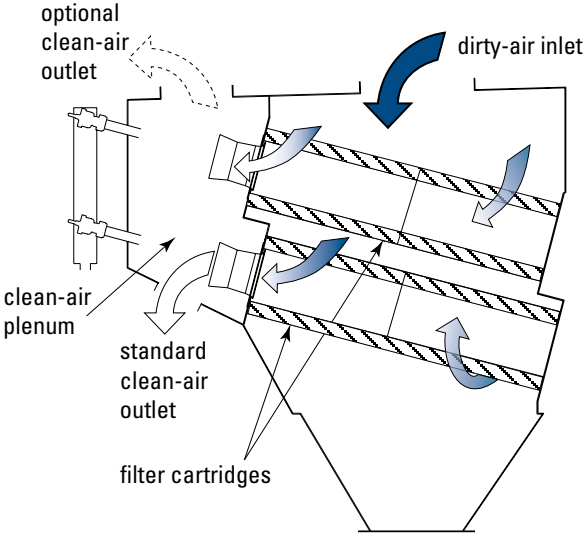

**SIMPLY
THE BEST**
CARTRIDGE COLLECTORS AVAILABLE



CARTRIDGE FILTER TECHNOLOGY

HIGH PERFORMANCE FILTERS

The Downflo Oval filter design is another indication of Donaldson Torit's commitment to technical research and development. The distinguishing factor in our filters is Ultra-Web® filtration technology. Ultra-Web nanofiber media uses a layer of fibers 0.2 to 0.3 microns in diameter to capture contaminants on the surface of the media less than one micron in size. The resulting dust cake is easily cleaned off during the automated collector cleaning cycles providing cleaner air longer, with a minimum MERV* 15 efficiency rating based on ASHRAE 52.2 - 2007 test standards.

10 micron



Nanofiber Media
(600x)

Nanofiber surface loading technology is available in all Ultra-Web and Fibra-Web filter cartridges.

10 micron

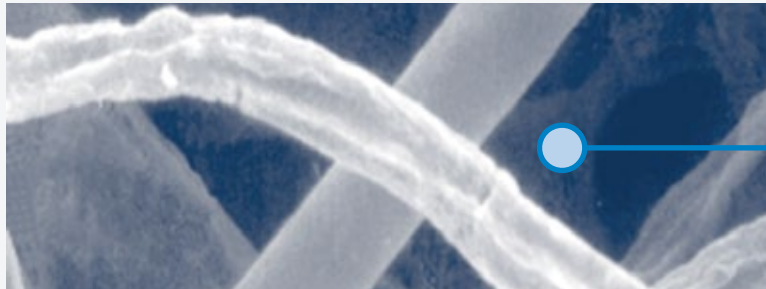

Commodity Filter Media
(600x)

Conventional media has spaces of up to 60 µm between fibers, allowing dust to become deeply embedded.

CARTRIDGE FILTERS FOR MANY APPLICATIONS

The Downflo WorkStation (DWS) in conjunction with Donaldson Torit's unique oval-shaped filter cartridges are an unbeatable system. Choose from our superior line of filters to complete the most powerful filtration solution available for your application.

MORE AIRFLOW, LESS FILTER MEDIA

UNIQUE OVAL SHAPE CONTRIBUTES TO HIGHER AIRFLOW CAPACITY

The Downflo Oval filter design is a reflection of Donaldson Torit’s commitment to technical research and development. High performance oval-shaped filters handle up to 25 percent more airflow without increasing velocities, which can cause filter abrasion. Sophisticated FLUENT®*Airflow Modeling Software revealed that oval-shaped cartridge filters have fewer areas of high velocity, resulting in a lower potential for media abrasion and increased filter life.

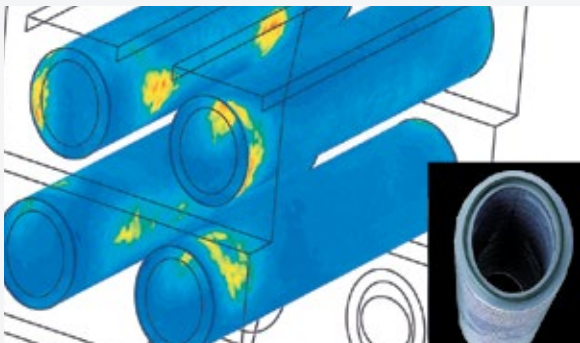

DOWNFLO OVAL COLLECTOR
9145 cfm (15,534 m³/h)

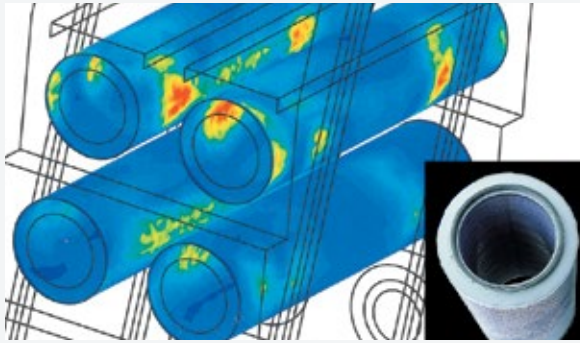

STANDARD COLLECTOR
7315 cfm (12,426 m³/h)

AIRFLOW BREAKTHROUGHS LEAD TO HIGHER FILTRATION EFFICIENCY

Sophisticated computer modeling for fluid dynamics, structural mechanics and acoustics puts DFO models 1-1, 2-2, and 3-3 in a technical class all their own. The illustration below (left) shows how FLUENT Flow Modeling Software enhanced the uniform air velocity distribution through model DFO 3-3. ANSYS®* Structure Analysis Software shown below (right) demonstrates lowest stress levels and deflections for model DFO 3-3 under typical operating pressures.

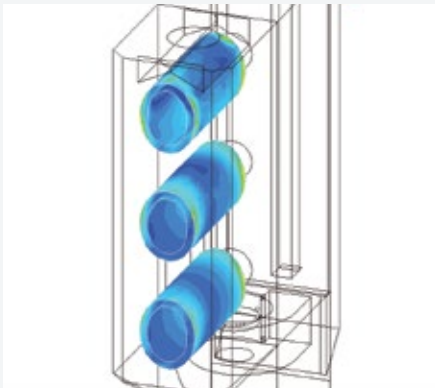

DFO 3-3 AIR VELOCITY DISTRIBUTION



DFO 3-3 STRESS AND DEFLECTIONS MODEL

* FLUENT is a registered trademark of Fluent, Inc.; ANSYS is a registered trademark of ANSYS, Inc.

BETTER FILTRATION, PROLONGED FILTER LIFE

CONVEX SIDE WALLS

Technical discoveries improve filtration performance and prolonged filter life. A new cabinet design with convex side walls streamlines the airflow path and increases the cabinet's cross-sectional area. The convex side walls provide more space between filters, lower cabinet velocities and reduce the potential for media abrasion.

SHOWN: CROSS-SECTIONAL AREA OF COLLECTOR DIRTY AIR PLENUM.

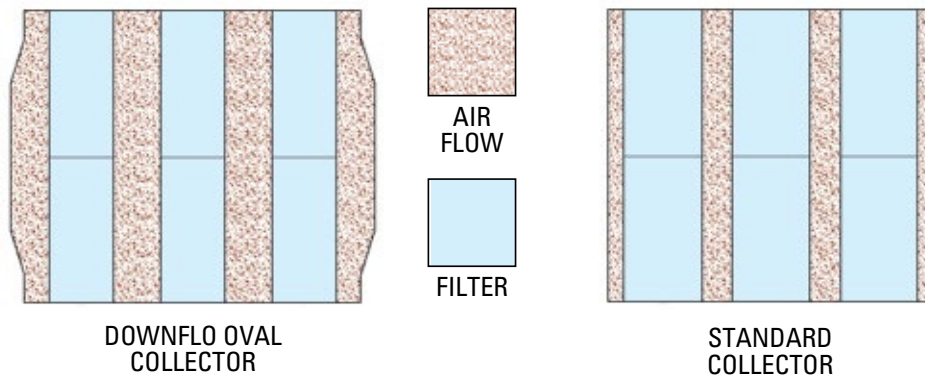

CROSS-SECTIONAL AREAS

PULSE CLEANING TECHNOLOGY

ExtraLife™ Filter Cleaning System uses proprietary, computer-modeled pulse cleaning technology to easily “pulse off” dust from the surface of the filter, improving filtration efficiency and prolonging filter life. The red lines in the illustration show the increased pressure at the front of the Downflo filter generated by the ExtraLife system. The blue line shows the pulse signature of a standard cartridge collector.

Pulse gradients produced by the standard Downflo during pulse cleaning compared to gradients produced by a Downflo with the ExtraLife Cleaning System (red).

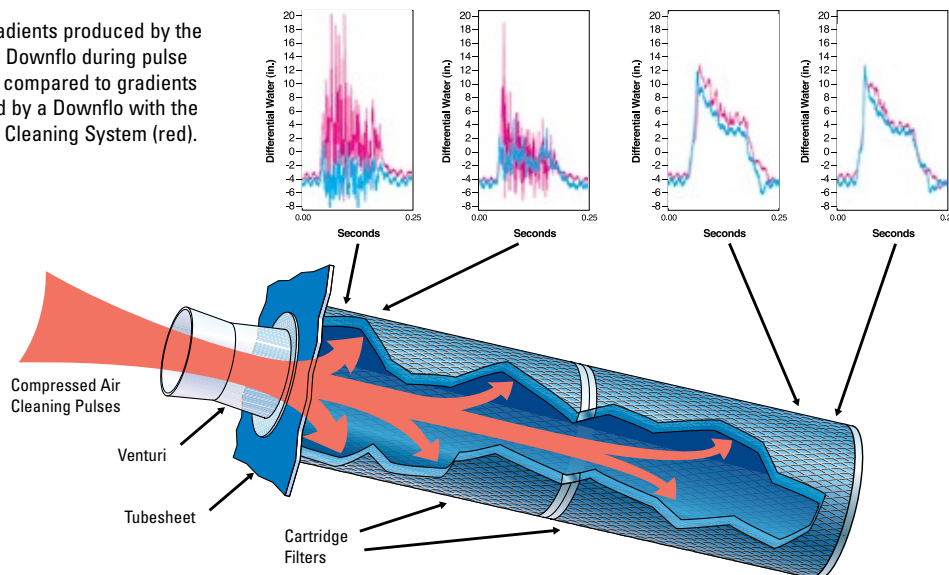

DOWNFLO PULSE PRESSURE GRADIENTS

FILTER CHANGES AND DISCHARGE MAINTENANCE

EASY MAINTENANCE

With the new design of the DFO's quick-release access handles, filter removal and maintenance is extremely fast with one simple movement of the clamp.



BAG-IN/BAG-OUT ARRANGEMENTS

Improve filter changeouts and hopper discharge maintenance, help minimize worker exposure to potentially harmful dusts, and reduce exposure of contaminants to the atmosphere.

- Porthole covers protect changeout bags and provide a clean appearance
- Heavy-duty plastic bags hold filters and function as gloves during the changeout procedure
- Filters are disposed of in a sealed bag
- Bag-in/Bag-Out drum arrangement is safely held in place through drum latches and hose clamps



OPERATING ADVANTAGES & CONDITIONS

DFO MODELS	1-1	2-2	3-3	2-4 THROUGH 4-128
Horsepower (HP)	1.5	3	5	**
Sound Level dB(A)*	68	68	70	**
External Static Pressure (in of H ₂ O/mm of H ₂ O)	***	***	***	**
Housing Construction (gauge)	12	12	12	10 (collector) 7 (tubesheet)
Housing Rating (in of H ₂ O/mm of H ₂ O)	-20/-508	-20/-508	-20/-508	-20/-508
Wind Load Rating (mph/kph)	—	—	—	100 / 161
Seismic Rating (zone)	4	4	4	4
Compressed Air Required (psi/bar)	60/4.1	60/4.1	60/4.1	2-4, 3-6: 60/4.1 2-8 and up: 90-100/6.2-6.9

* Sound measurements were taken in a hemianechoic chamber and under free field conditions and do not reflect the influences of actual operating environments. Standard sound pressure levels were taken at an operator position of 1.5 m high and 1 m from source.

** Provided through Donaldson Torit fan program.

*** See system performance curves on page 10.



ADDRESSING SAFETY CONCEPTS

Donaldson Torit manufactures or partners with experts to provide solutions for critical processes where harmful particulate must be controlled.

- Explosion Relief Panels (with or without weather domes)
- Suppression Systems
- Reinforced Housing Construction

SYSTEM CURVES FOR DFO MODELS 1-1, 2-2, AND 3-3

POWERFUL PERFORMANCE

Unlike other technologies that require upgrades for more demanding applications, each DFO 1-1, 2-2 and 3-3 footprint comes standard with a unique high performance power pack. The system performance graphs below show the fan performance with clean filters. The curve indicates available external static pressure to the unit.

DFO 1-1 1.5HP 60Hz with 6" (152.4 mm) inlet duct (clean filter)

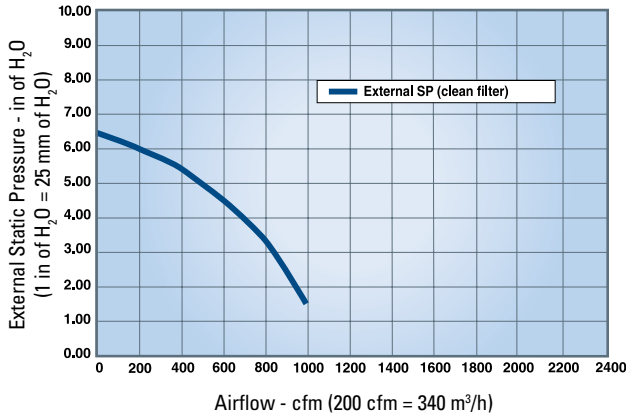

DFO 1-1 1.1kW 50Hz with 6" (152.4 mm) inlet duct (clean filter)

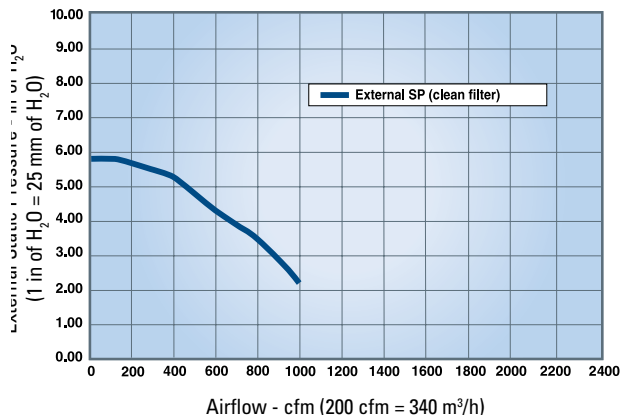

DFO 2-2 3HP 60Hz with 8" (203.2 mm) inlet duct (clean filters)

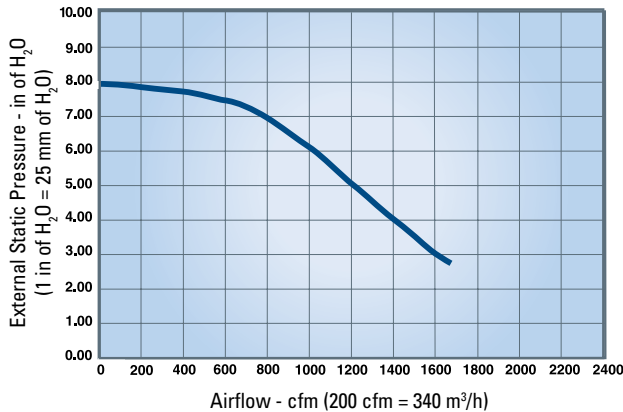

DFO 2-2 2.2kW 50Hz with 8" (203.2 mm) inlet duct (clean filters)

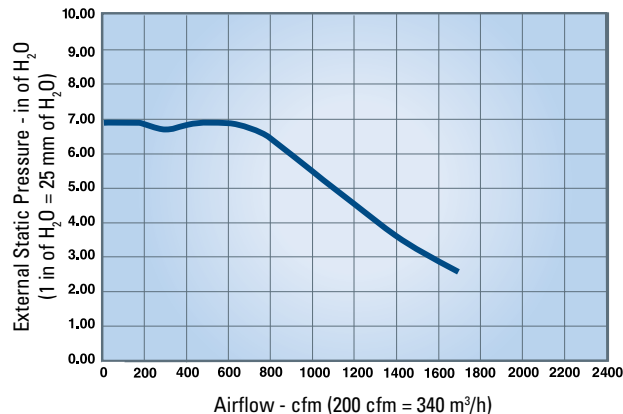

DFO 3-3 5HP 60Hz with 9" (228.6 mm) inlet duct (clean filters)

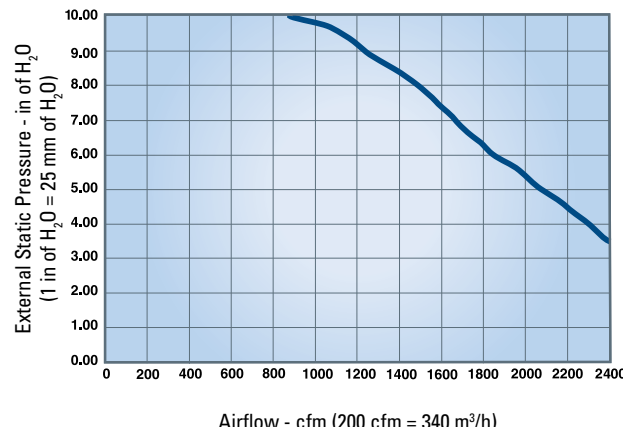

DFO 3-3 4.0kW 50Hz with 9" (228.6 mm) inlet duct (clean filters)

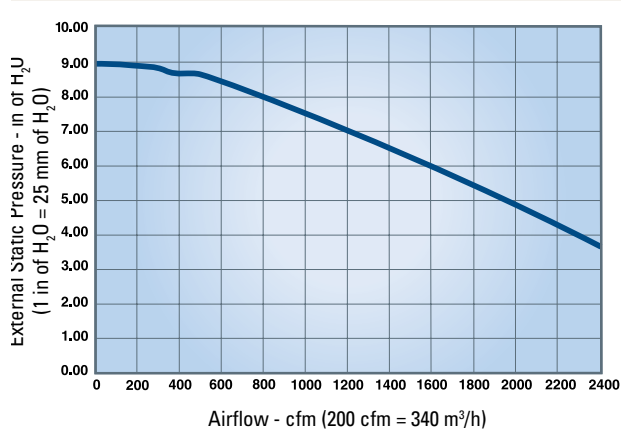

DIMENSIONS & SPECIFICATIONS

BASE MODULES

1-1, 2-2 & 3-3

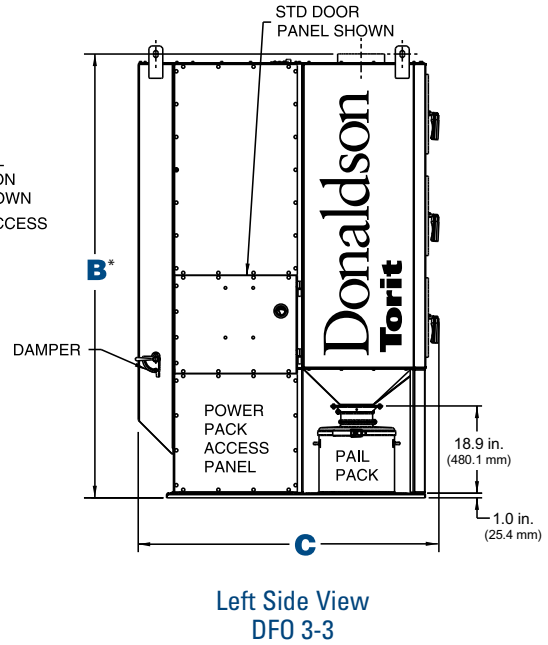
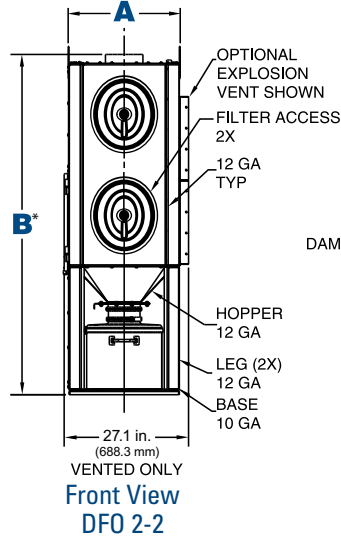
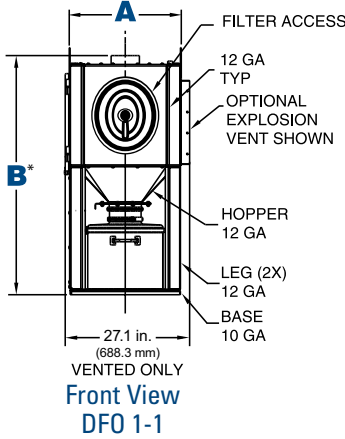

* Top of inlets.

BASE MODULES

2-4 TO 4-128

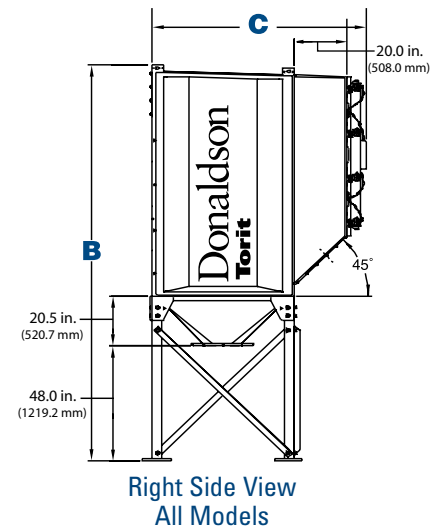
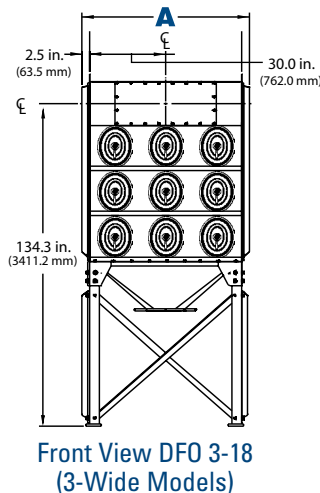
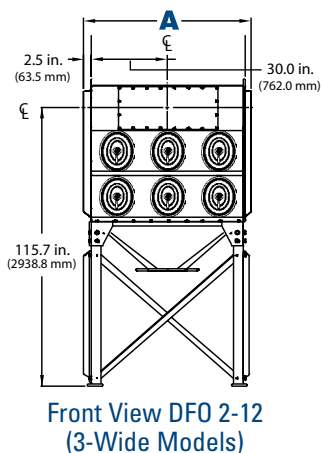
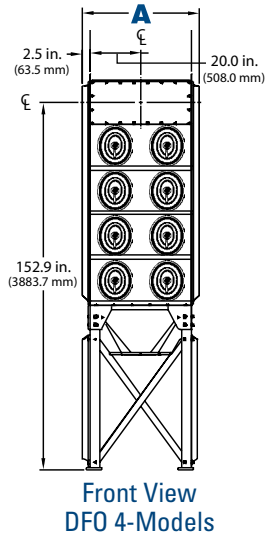
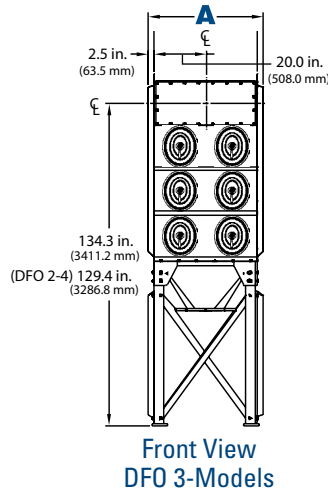
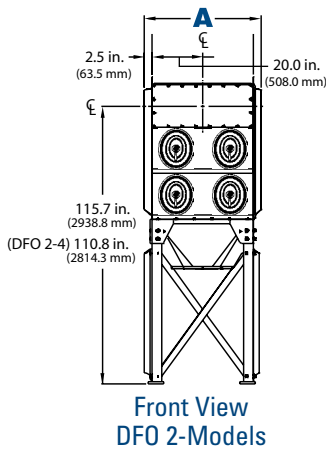

DFO Model*	Nominal Airflow Range**		No. of Filters	Ultra-Web Filter Area		No. of Valves	Approx. Shipping Weight***		Dimensions					
									A		B		C	
	cfm	m ³ /h		ft ²	m ²		lb	kg	in	mm	in	mm	in	mm
1-1	100-800	169.9-1,358.9	1	190	17.7	1	800	362.9	30.0	762.0	52.0	1320.8	65.0	1651.0
2-2	200-1,600	339.7-2,717.8	2	380	35.3	2	1,000	453.6	30.0	762.0	74.0	1879.6	65.0	1651.0
3-3	300-2,400	509.6-4,076.8	3	570	53.0	3	1,300	589.7	30.0	762.0	96.0	2438.4	65.0	1651.0
2-4	380-3,190	645.5-5,418.7	4	760	70.6	4	1,100	499.0	45.0	1143.0	118.8	3017.5	62.0	1574.8
2-8	760-6,380	1,291.0-10,837.4	8	1,520	141.2	4	1,600	725.7	45.0	1143.0	127.8	3246.1	84.0	2133.6
2-12	1,140-9,580	1,936.5-16,273.1	12	2,280	211.8	6	2,100	952.5	65.0	1651.0	127.8	3246.1	84.0	2133.6
2-16	1,520-12,770	2,581.9-21,691.8	16	3,040	282.4	8	3,100	1,406.1	85.0	2159.0	127.8	3246.1	84.0	2133.6
2-24	2,280-19,150	3,872.9-32,529.1	24	4,560	423.6	12	4,200	1,905.1	125.0	3175.0	127.8	3246.1	84.0	2133.6
2-36	3,420-28,730	5,809.4-48,802.2	36	6,840	635.4	18	6,300	2,857.6	185.0	4699.0	127.8	3246.1	84.0	2133.6
3-6	570-4,790	968.2-8,136.5	6	1,140	105.9	6	1,400	635.0	45.0	1143.0	137.4	3490.0	62.0	1574.8
3-10	950-7,980	1,613.7-13,555.2	10	1,900	176.5	5	1,900	861.8	45.0	1143.0	146.5	3721.1	85.3	2166.6
3-12	1,140-9,580	1,936.5-16,273.1	12	2,280	211.8	6	2,000	907.2	45.0	1143.0	146.5	3721.1	85.3	2166.6
3-18	1,710-14,370	2,904.7-24,409.6	18	3,420	317.7	9	2,800	1,270.1	65.0	1651.0	146.5	3721.1	85.3	2166.6
3-24	2,280-19,150	3,872.9-32,529.1	24	4,560	423.6	12	3,300	1,496.9	85.0	2159.0	146.5	3721.1	85.3	2166.6
3-36	3,420-28,730	5,809.4-48,802.2	36	6,840	635.4	18	6,100	2,766.9	125.0	3175.0	146.5	3721.1	85.3	2166.6
3-48	4,560-38,300	7,745.8-65,058.3	48	9,120	847.2	24	8,100	3,674.1	165.0	4191.0	146.5	3721.1	85.3	2166.6
3-60	5,700-47,880	9,682.3-81,331.4	60	11,400	1,059.1	30	10,100	4,581.3	205.0	5207.0	146.5	3721.1	85.3	2166.6
3-72	6,840-57,460	11,618.8-97,604.4	72	13,680	1,270.9	36	12,100	5,488.5	245.0	6223.0	146.5	3721.1	85.3	2166.6
4-16	1,520-12,770	2,581.9-21,691.8	16	3,040	282.4	8	2,400	1,088.6	45.0	1143.0	165.1	4193.5	85.3	2166.6
4-32	3,040-25,540	5,163.9-43,383.5	32	6,080	564.8	16	4,200	1,905.1	85.0	2159.0	165.1	4193.5	85.3	2166.6
4-48	4,560-38,300	7,745.8-65,058.3	48	9,120	847.2	24	7,400	3,356.6	125.0	3175.0	165.1	4193.5	85.3	2166.6
4-64	6,080-51,070	10,327.8-86,750.1	64	12,160	1,129.7	32	9,100	4,127.7	165.0	4191.0	165.1	4193.5	85.3	2166.6
4-80	7,600-63,840	12,909.7-108,441.8	80	15,200	1,412.1	40	11,000	4,989.5	205.0	5207.0	165.1	4193.5	85.3	2166.6
4-96	9,120-76,600	15,491.7-130,116.6	96	18,240	1,694.5	48	12,600	5,715.3	245.0	6223.0	165.1	4193.5	85.3	2166.6
4-112	10,640-89,380	18,073.6-151,825.3	112	21,280	1,976.9	56	14,500	6,577.1	285.0	7239.0	165.1	4193.5	85.3	2166.6
4-128	12,160-102,150	20,655.6-173,517.1	128	24,320	2,259.3	64	16,100	7,302.8	325.0	8255.0	165.1	4193.5	85.3	2166.6

* The first number indicates number of filter rows, and the second number indicates number of cartridges.

** Based on clean filters.

*** Without accessories or optional equipment.

PROVEN PERFORMANCE ON HUNDREDS OF APPLICATIONS



DFO 3-6 on Sawing of High Pressure Hydraulic Hose



DFO 2-4 on Fiberglass Routing & Cutting



DFO 4-112 on Titanium Grinding



DFO 4-48 on Metal Grinding



DFO 2-2 on Paint Pigment Dust

STANDARD FEATURES & AVAILABLE OPTIONS

DFO 1-1, 2-2, 3-3

Collector Design †	Std	Opt
Mild Steel Construction	X	
Integral High Performance Power Packs	X	
Ledge-Free Hopper	X	
Inlet	X	
Sprinkler Taps	X	
ExtraLife™ Filter Cleaning System	X	
Quick-Removal Access Covers	X	
Integral Exhaust Silencer	X	
Airflow Damper	X	
Stainless Steel Construction		X
Explosion Protected Models		X
High Static Power Packs		X
Inlet Damper		X
Abrasion Resistant (AR) Inlet		X
Sprinkler Heads		X
Extraction Arms		X
Caster Packs		X
Bag-Out Kit (Filter & Discharge)		X
Bag-In/Bag-Out Kit (Filter & Discharge)		X
Cartridge Filters		
Ultra-Web® (MERV* 15)	X	
Fibra-Web® (MERV 14); Ultra-Tek® (MERV 12); Ultra-Web® AS (MERV 15); Ultra-Web® SB (MERV 15); Thermo-Web™ (MERV 14); Torit-Tex™ (MERV 16)		X
HEPA/ASHRAE Afterfilters		X
Paint System		
Textured Multi-Coat Paint Finish with 2,000-Hour Salt Spray Performance	X	
Custom Color		X
Premium Duty Finish		X
Epoxy Coating		X
Hopper Discharge		
10-Gallon (37.9-Liter) Pail Pack	X	
10-Gallon (37.9-Liter) Pail Pack with Sealer Gear		X
25-Gallon (94.6-Liter) Dust Container		X
Electrical Controls, Gauges & Enclosures		
Minihelic®** Gauge	X	
Manual or Automated Downtime Cleaning	X	
Solenoid Enclosure in NEMA 12	X	
Continuous On-Demand Delta P Control		X
Solenoid Enclosure NEMA 9		X
Starter Controls		X
Warranty		
10-Year Warranty	X	

* The Minimum Efficiency Reporting Value (MERV) of this filter cartridge has been determined through independent laboratory testing using ASHRAE 52.2 (2007) test standards. The MERV rating was determined at a face velocity of 118 feet (36.0 m) per minute and loading up to four inches (101.6 mm) water gauge. Actual efficiency of any filter cartridge will vary according to the specific application parameters. Dust concentration, airflow, particle characteristics, and pulse cleaning methods all affect filtration efficiency.

† Donaldson Torit equipment is designed to IBC guidelines for specific wind speed exposure and seismic spectral acceleration at grade level. Contact your Donaldson Torit representative for detailed information available on the equipment's Spec Control drawings. Equipment may be customized to meet unique, customer-specified site requirements.

DFO 2-4 TO 4-128

Collector Design †	Std	Opt
Mild Steel Construction	X	
ExtraLife™ Filter Cleaning System	X	
Quick-Removal Access Covers	X	
Inlets	X	
Ledge-Free Hopper	X	
Sprinkler Taps	X	
Stainless Steel Construction		X
High Temperature Construction		X
Explosion Protected Models		X
Direct Drive Fans		X
Chamber and Exhaust Silencers		X
Abrasion Resistant (AR) Inlet		X
Air Management Modules		X
Extended Dirty Air Plenum		X
Steep-Sided Hopper		X
2-Mod Hopper		X
Sprinkler Heads		X
Service Platform (OSHA compliant)		X
Damper Pack		X
Drum Sentry™ Drum-Full Indicator		X
Lined Clean Air Plenum		X
Bag-Out Kit (Filter & Discharge)		X
Bag-In/Bag-Out Kit (Filter & Discharge)		X
Cartridge Filters		
Ultra-Web® (MERV* 15)	X	
Fibra-Web® (MERV 14); Ultra-Tek® (MERV 12); Ultra-Web® AS (MERV 15); Thermo-Web™ (MERV 14); Torit-Tex™ (MERV 16)		X
HEPA/ASHRAE Afterfilters		X
Paint System		
Prime Coated Interior	X	
Textured Multi-Coat Paint Finish with 2,000-Hour Salt Spray Performance	X	
Custom Color		X
Premium Duty Finish		X
Epoxy Coating		X
Hopper Discharge		
Drum Cover and Hose		X
Slide Gates		X
Rotary Valves and Transitions		X
Screw Conveyors		X
Electrical Controls, Gauges & Enclosures		
Control Box w/Timer in NEMA 4 Enclosure	X	
Magnehelic®** Gauge Controls	X	
Delta P Control, Delta P Plus Control		X
Dustronix™ Control Assembly		X
Custom Panels		X
Photohelic®*** Gauge Standard and Weatherproof		X
Basic Cold Climate Kit		X
Heavy-Duty Cold Climate Kit		X
Solenoid Enclosure (NEMA 7 & 9)		X
Warranty		
10-Year Warranty	X	

** Minihelic, Magnehelic and Photohelic are registered trademarks of Dwyer Instruments, Inc.

Global Support

- Facilities in 37 countries
- 40 manufacturing plants and 14 distribution centers

Leading Technology

- Over 1,000 engineers and scientists worldwide
- Broad range of innovative collectors and filters
- 100s of filter media formulations

Experience and Service

- Technical expertise and support
- Ready-to-ship filters and parts within 24 hours

Call Donaldson® Torit® to get cleaner air today:

800-365-1331

DonaldsonTorit.com



Tel 800-365-1331 (USA)
Tel 800-343-3639 (within Mexico)
donaldsontorit@donaldson.com
donaldsontorit.com

Donaldson Company, Inc.
Torit
P.O. Box 1299
Minneapolis, MN
55440-1299 U.S.A.

EXACTLY WHAT YOU NEED.™

Downflo Oval Dust Collectors (12/15)
© 2015 Donaldson Company, Inc. All Rights Reserved. All products, product specifications, and data (airflow, capacity, dimensions, or availability) are subject to change without notice, and may vary by region or country. Donaldson Torit, Downflo, Ultra-Web, and the color blue are registered trademarks of Donaldson Company, Inc. Contains Donaldson proprietary technology.